



Omgivelseskontroll
Dokumentasjon for Dørautomatikk

Picomatic 2202

Picomatic 2301

Picomatic 2302

Picomatic 2401

**(Tormax 2202, 2301, 2302 og 2401 for
omgivelseskontroll)**

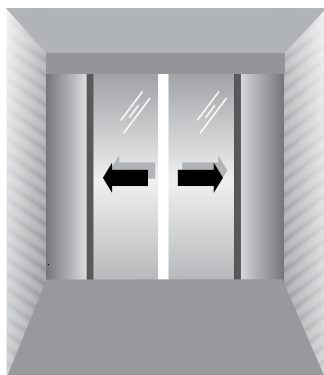

Instructions for Use

For Automatic Sliding Doors with Drive

iMotion® 2202 Sliding Door Drive

iMotion® 2202.A Sliding Door Drive

iMotion® 2301/2301.IP65 Sliding Door Drive

iMotion® 2302 Sliding Door Drive

iMotion® 2401/2401.IP65 Sliding Door Drive

Contents

1	General Information	3
1.1	Target Groups	3
1.2	Storage and dissemination of the manual	3
1.3	Area of Application	3
1.4	Explanation of the Symbols	4
1.5	Technical Data	4
2	Safety	5
2.1	Responsibilities	5
2.2	Use for the Purpose Intended	5
2.3	Pre-conditions for the Operation of the System	5
2.4	Hazards and Risks	5
2.5	Checks	6
2.6	Taking the System out of Service in the Event of a Fault	6
2.7	Disposal	7
3	Product Description	8
3.1	System Overview	8
3.2	System Function	9
3.3	Operating Modes	10
4	Operation	11
4.1	Commissioning	11
4.2	Operation with the TORMAX User Interface	11
4.3	Operation with an Operating Mode Switch	12
4.4	Operation on Power Failure	12
5	Procedure in the Event of a Fault	13
6	Maintenance	14
6.1	Cleaning	14
6.2	Functional Checks	14
6.3	Maintenance and Testing	14
7	Appendix	15
7.1	Fault Table	15
7.2	Check-list for Functional Checks	17
	Declaration of Conformity	18

First edition: 10.08, Update: 3.11, 2.12, 12.13

We reserve the right to make technical changes.

Printed on environmentally friendly paper bleached without the use of chlorine.

Landert Motoren AG and Landert GmbH are certified to ISO 9001.

1 General Information

1.1 Target Groups

- Operator of the automatic door. The operator is the person responsible for the operation and maintenance of the system.
- Persons instructed by the operator to carry out certain duties, for example the servicing and maintenance of the automatic sliding door.

1.2 Storage and forwarding of the manual

- Store the instructions for use in the vicinity of the automatic door system.
- If the manual has become illegible due to constant usage, reorder the instructions.
- When the door system is transferred or resold to a third party, pass the following documents to the new owner:
 - This instructions for use
 - Documentation concerning modification and repair work
 - Proof of the regular examinations → System test book T-879



1.3 Area of Application

Product name, door system: Automatic sliding door

Product name, door drive: **iMotion® 2202 Sliding Door Drive**
iMotion® 2202.A Sliding Door Drive
iMotion® 2301 / 2301.IP65 Sliding Door Drive
iMotion® 2302 Sliding Door Drive
iMotion® 2401 / 2401.IP65 Sliding Door Drive

Serial number:

Identification plate
(example)

		Landert Motoren AG Unterweg 14 CH-8180 Bülach								
Model: iMotion 2302 Sliding Door Drive										
DIN18650-1:2010		2	3	2	0	123	0	2	EN16005:2012	
Un: 230V AC 50Hz ... 60Hz		IP 22		T _A -20°C ... +50°C						
P _{max.} : 190W		I _{max.} : 1.0A		Pedestrian Door Operator				Serial No.:		
P _{mn.} : 8W		I _{min.} : 0.1A		Manufactured: 10/2013						
Weight of door leaves: 1x<200kg (1leaf), 2x<180kg (2leaves)										

The identification plate with the serial number is attached to the header section.

1.4 Explanation of the Symbols



Warning (signal word)

Source of hazard (designates a possibly hazardous situation)

Possible consequences of non-observance

- Measures for averting danger.

Text which is highlighted in grey MUST be observed to ensure that the system operates perfectly. Failure to observe these sections can cause damage to equipment.



Functions marked with this symbol are the factory setting. However, they can be reprogrammed by a specialist.



Optional components which are not present in all systems.

1.5 Technical Data

Drive type	Electro-mechanical sliding door drive with direct drive (iMotion 2301, 2302, 2401) using an AC permanent magnet synchronous motor
Control system	Control unit MCU32
Mains connection	1 x 230 VAC, 50–60 Hz, 10 A / 1 x 115 VAC, 50–60 Hz, 15 A
Power consumption	iMotion 2202, 2301, 2302: max. 190 W iMotion 2301.IP65: max. 240 W iMotion 2401: max. 310 W iMotion 2401.IP65: max. 350 W
Sensor supply	iMotion 2202, 2301, 2302: 24 V DC (+0,5–1,5V) 0,75 A in battery operation min. 16,5V iMotion 2401: 24 V DC (+0,5–1,5V) 1,5 A in battery operation min. 16,5V iMotion 2301.IP65: 0,75 A iMotion 2401.IP65: 1,5 A to +30 °C, 1,0 A to +50 °C
Protective class, drive	IP 22 (IP65 for iMotion 2301.IP65 and 2401.IP65)
Fusible	5 AT
Ambient temperature	–20 °C to +50 °C
Noise emission level	< 70 db(A)

2 Safety

2.1 Responsibilities

For instructing the operator:	A specialist from a TORMAX sales partner
For operating the system:	The operator or a person instructed by the operator
For maintenance and function control:	The operator or a person instructed by the operator
For annual testing and approval:	A specialist authorised by the manufacturer

Specialists are persons who have adequate knowledge in the field of power-operated doors as a result of their specialist training and experience and who are so familiar with the relevant health and safety regulations, guide-lines and generally recognised codes of practice that they are able to assess the condition of power-operated doors with regard to the safety of their operation.

Maintenance of electrical parts must be carried out by a trained electrician.

2.2 Use for the Purpose Intended

The automatic sliding door is intended exclusively for use in dry premises in areas used as a pedestrian thoroughfare. The manufacturer will not accept any liability whatsoever for loss or damage caused by improper use, failure to comply with the maintenance specification (see section 6) or unauthorised modification of the system.

2.3 Pre-conditions for the Operation of the System

The door system was designed, installed and checked for functionality and safety by specialists prior to hand-over to the operator. The company responsible for the system's installation instructed the operator on the system's use and maintenance as well dangers associated with the system operation. The operator has confirmed this by his signature in the system test book T-879.

The provisions imposed by law, health and safety and occupational health regulations for the avoidance of accidents and the protection of the environment which are generally applicable in the country in which the system is operated supplement the instructions for use.

- Read the instructions for use carefully before commissioning the automatic sliding door.
- Only use the system when it is in perfect working order. The operating conditions, inspection and maintenance intervals stipulated by the manufacturer must be observed (section 6).
- Safety facilities (e.g. sensor technology, manual unlocking) must not be removed or disabled.
- Arrange to have any faults rectified immediately by a specialist.

2.4 Hazards and Risks

Depending on the system design and equipment, there is a residual risk of crushing, entanglement and collision in the movement area of the door leaves – albeit with restricted force.

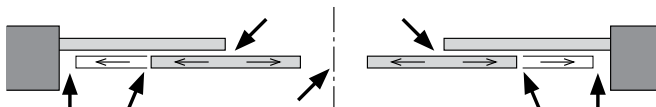



Warning

Danger through moving parts:

- in the area of all closing edges
- in the gap for suspending the door in the cladding
- when objects such as, for example, display shelves are erected in the direct proximity of the moving part of the door leaf.

Risk of injury

- Do not allow children to play in the direct proximity of the automatic door.
- Children may not operate the existing operating units.



Warning

Hazards can arise due to deliberate damage, incorrect installation, defective sensors or sensors which are longer properly adjusted, sharp edges, incorrectly mounted and defective casing or missing covers.

- Danger for body and life, danger of injury
- Have system repaired by a qualified person

2.5 Checks

The regular checks and examinations set out in Chapter 6 must be carried out as instructed by the manufacturer. The manufacturer recommends that a maintenance contract be concluded in order to operate the system safely and to maintain its value for as long as possible.

2.6 Taking the System out of Service in the Event of a Fault

If there is a fault the automatic door may only be taken out of service by a specialist, the operator or a person who is instructed to do so by the operator. This must be done on all occasions on which the safety of persons could be compromised.

- Disconnect the system from the power supply.
- Select operating mode "P" if the system is nevertheless to continue to be operated using the internal emergency power supply (see section 3.3 for operating modes).
- Open the door manually and leave open if it is installed in an escape route.

See section 7 for rectification of faults.

2.7 Disposal

This system must be properly dismantled at the end of its working life. Its disposal must comply with national regulations. We recommend that you contact a specialist disposal company.



Warning

Aggressive acids

Risk of injury if you dismantle the battery module.

- Dispose of batteries properly.



Warning

Broken glass

Risk of injury when dismantling the door leaves.

- Take care when transporting the door leaves.

3 Product Description

3.1 System Overview

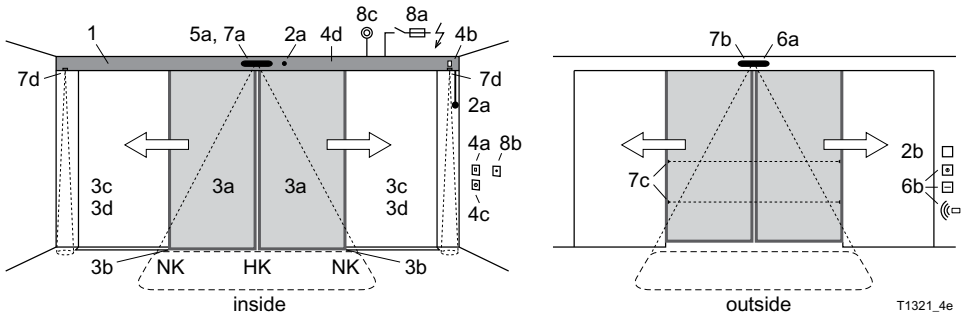

T1321_4e

1	Drive	Cladding Motor unit MCU32 control system with monitoring system, power limitation and permanent diagnosis Guide system with noise-absorbent guide rail
2	Drive accessories ◆	<input type="checkbox"/> Lock with a) <input type="checkbox"/> internal manual activation <input type="checkbox"/> in the cladding <input type="checkbox"/> on the wall b) <input type="checkbox"/> external manual activation <input type="checkbox"/> Emergency power supply via the battery unit <input type="checkbox"/> Mechanical emergency opening
3	Door leaves	a) Moving leaves with main closing edge (HK) and secondary closing edge (NK) b) Moving leaves with floor guide c) <input type="checkbox"/> Side part ◆ d) <input type="checkbox"/> Protection leaves ◆ as protection for the secondary closing edge
4	Operating controls	a) <input type="checkbox"/> iMotion user interface with 6 operating modes and fault display b) <input type="checkbox"/> Operating mode switch with 3 positions. c) <input type="checkbox"/> Lock for the user interface d) <input type="checkbox"/> Remote control of operating modes
5	Internal activators	a) With automatic activation <input type="checkbox"/> Radar with/without direction recognition <input type="checkbox"/> IR motion detector b) With manual activation <input type="checkbox"/> Push button <input type="checkbox"/> Contact-free button
6	External activators	a) With automatic activation <input type="checkbox"/> Radar with/without direction recognition <input type="checkbox"/> IR motion detector b) With manual activation <input type="checkbox"/> Key switch <input type="checkbox"/> Card reader <input type="checkbox"/> Remote control
7	Safety sensors	a) <input type="checkbox"/> Presence sensor: main closing edge protection b) <input type="checkbox"/> Presence sensor, external: main closing edge protection c) <input type="checkbox"/> Safety beams d) <input type="checkbox"/> Presence sensors: secondary closing edge protection
8	Emergency systems	a) <input type="checkbox"/> Power switch /fuse b) <input type="checkbox"/> Emergency on/off switch c) <input type="checkbox"/> Fire alarm system
9	Output message ◆	<input type="checkbox"/> Bell/gong <input type="checkbox"/> Light/ventilation <input type="checkbox"/> Door locked <input type="checkbox"/> Door status

Depending on the system's equipment

3.2 System Function

It is the responsibility of the system operator to ensure that the automatic sliding door can be freely used at all times and particularly that access to the sliding door is not blocked.

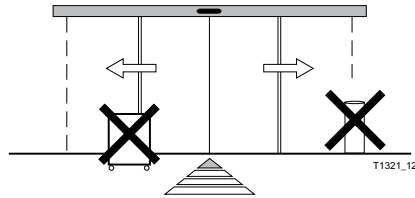

Automatic Door Operation with Sensors

When operating automatically (AUTOMATIC operating mode) the door is automatically opened from both sides by sensors when a person approaches.

A key switch ◆ or card reader ◆ normally allows access from outside when the door is in operating mode EXIT or OFF. The door unlocks, opens and closes again as soon as no further sensors are activated after a hold-open time which is set separately.

The sensors for the door opening and the maintained opening of the door are arranged and adjusted in such a way that the door opens promptly and remains open as long as a person is within the operating range of the door leaves. The door can close nevertheless but only after an attendance time of approx. > 1 minute.

The reduced closing speed which is set by the installer and is adjusted in line with the door weight, combined with a force of < 150 N prevents the impact of the moving leaves on a person from being too severe. The obstruction is also detected by the control system and the door automatically reverses.

Traffic Control

Movement through the door can be allowed in only one direction if desired (operating mode EXIT) or completely blocked (operating mode OFF).

In order to protect against environmental influences (wind/cold/heat) the door can be operated in operating mode AUTOMATIC 2 with a restricted opening width which is not less than the required escape route width.

Automatic System Monitoring

The control system monitors the safety sensors by a cycle of active tests. The control system also conducts continuous internal system tests. If a safety-related component should fail, the system automatically switches into a safe condition. At the same time the fault number is displayed on the user interface. You can find further information on this subject in section 5 "Procedure in the Event of Faults".

Electro-mechanical Lock ◆

The system can be locked in the closed position by means of an electro-mechanical lock ◆ or held in the closed position by a holding magnet ◆ when in operating mode OFF and, if required, in other operating modes (e.g. EXIT).

The locking process is monitored. Thus any fault of the locking operation can be immediately displayed on the user interface. See section 5 "Procedure in the Event of Faults" for details.

In the event of a power failure the locks can also be directly activated by the optional manual facility.

Operation in the Event of a Power Failure

Depending on the equipment installed, the following functions are possible:

- Immediate emergency opening or closing by a mechanical energy store ◆.

- Immediate unlocking (only if programmed by the installer).
- Continued operation of the system by means of a battery unit ♦ for a specific time with the doors opening before the battery switches off. The door remains locked in operating mode OFF.
- Unlocking and opening of the door from outside by means of a key switch and the battery unit ♦.

3.3 Operating Modes

By using the TORMAX user interface ♦ it is possible to operate the automatic door system in 6 operating modes and with status displays or to use a simple operating mode switch ♦ to operate the door in 3 operating modes.

Operating Mode OFF

The internal and external sensors are disregarded. The door is maintained in the closed position either by the motor or the holding magnet ♦ and/or locked by the electro-mechanical lock ♦. Access is only possible using the key switch ♦.

 The door can still be used for 5 seconds after selecting operating mode OFF. The door then locks at the end of this period as soon as it is closed. The transition is signalled on the user interface by the flashing display of operating mode OFF.

Operating Mode AUTOMATIC 1

The operating mode AUTOMATIC 1 is normally used during the day. The door opens automatically (normally to its full opening width) to both sides by means of the internal and external sensors.

Operating Mode AUTOMATIC 2

Operating mode AUTOMATIC 2 is normally used during the day. The door opens automatically (normally with a reduced opening width) to both sides by means of the internal and external sensors.

 If required, the hold open time can be set by the installer for a different period to the one used in AUTOMATIC 1.

Operating Mode EXIT

Operating mode EXIT is normally used for the period before the shop or office closes. The door will only open automatically when activated by the internal sensor.

When the door opens the external sensor is also monitored for safety reasons.

The opening width is determined by previously selecting operating mode AUTOMATIC 1 or AUTOMATIC 2. The door can be automatically blocked using the holding magnet ♦.

Operating Mode OPEN

The door opens and remains open. The opening width is determined by previously selecting operating mode AUTOMATIC 1 or AUTOMATIC 2.

P **Operating Mode Manual Operation**

The door leaves can be freely moved. This operating mode can be used for cleaning the door leaves and the floor guide or for temporarily shutting down the door. The system is reset after leaving this operating mode.

4 Operation

The automatic sliding door may only be operated by a specialist, the operator or a person instructed by the operator.

4.1 Commissioning

Before switching on the mains power supply:

- Unlock the optional mechanical door lock e.g. floor lock.
- Check that the movement area of the door leaves is free from objects e.g. umbrella stands or vehicles.
- Check that the floor guide (particularly if it is continuous) is clean and not blocked by anything (e.g. gravel or snow).
- Switch on the mains power supply and select operating mode AUTOMATIC 1, for example.
 - The first movement after switching the power on for the first time is slow and H61/H62 is displayed. The control system is checking the door leaf's travel distance and defining the end position.
 - The door is now ready for operation.

4.2 Operation with the TORMAX User Interface

TORMAX User Interface

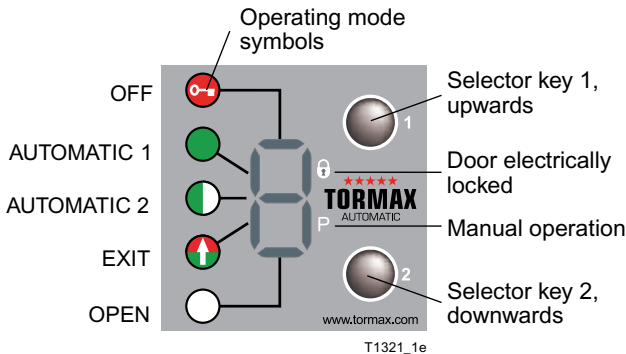

Lock ♦ for User Interface

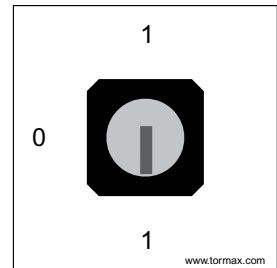

Unlocking of operating unit

The operating unit can be protected against unauthorised access by way of the lock ♦ or the code lock.

- Unlock lock = position 0

or

- Enter code ... / ... / ... using operating unit. Standard code = 3/3/3. The code can be determined by the engineer.
Example with code 3/3/3. Press upper selection button 3 times, then press the lower selection button 3 times and the upper selection button within 15 s . In case of entering wrong code: Wait at least 5 s . After successfully entering the code, the operating unit will be released within 60 s. The type of operation can be adjusted. Access will be automatically blocked again for 60 s after the button has been pressed for the last time.

Selection of Operating Modes

- Press selector keys 1 or 2 briefly. The corresponding operating mode symbol is illuminated.

Fault Display

E.g. H31 or E11 → See section 7 for the meaning of the display.

- Reset by pressing the selector key 2 briefly.

Resetting the System

- Press the selector key 2 for at least 2 seconds.

The software is restarted. The control system then conducts a calibration run, checks the travel distance and looks for the end position again. Displayed as H61 and H62.

4.3 Operation with an Operating Mode Switch

Selection of Operating Modes

The operating mode can be set directly.

(Reset the system after disconnecting the power supply for at least 5 seconds.)

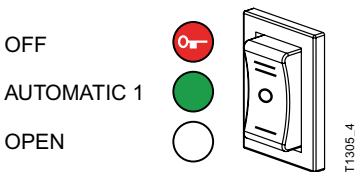

4.4 Operation on Power Failure

Manual Locking ◆

- Turn the manual operation knob clockwise (iMotion 2301, 2302, 2401) or press the manual operation lever inwards (iMotion 2202).
- Push the door closed by hand until the latch engages.

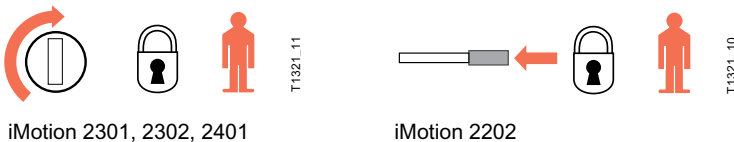

- Switch the operating mode switch to operating mode OFF. If a TORMAX user interface is used, operating mode OFF is automatically set when power is reconnected as the lock is engaged.

Manual Unlocking ◆

- Turn the manual operation knob anti-clockwise (iMotion 2301, 2302, 2401) or pull the manual operation lever outwards (iMotion 2202).

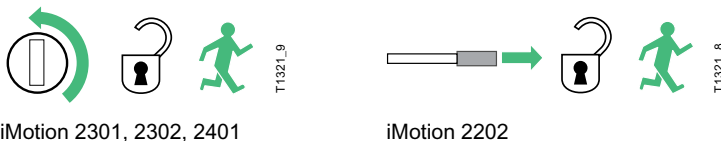

- Push the door open by hand.
- Set the operating mode switch to the operating mode you want when power is restored.

Opening a Door with a Battery Unit ♦ Using a Key Switch ♦

- Turn the key switch to the “on” position and hold in place for at least 3 seconds, then turn the key to the original position.
→ The battery is activated using the “wake up” function.
- Turn the key briefly to the “on” position once more. If required, the operating mode can be changed on the user interface during the wake-up.

The key switch must not remain permanently in the “on” opposition.

- The door is unlocked and opened.
- The battery switches off again.

5 Procedure in the Event of a Fault

Faults are evident from abnormal door behaviour and/or as an error message on the user interface. Error messages on the user interface take the form of a flashing “E” or “H” followed by two figures.

H = notification > the system can continue to be used.

E = fault > the system is stationary.

Some faults or notifications can be rectified by restarting the door drive with a software reset and/or briefly disconnecting the system from the power supply.

Fault Display and Reset Using the TORMAX User Interface

See the table in section 7.1 for an overview of the fault displays.

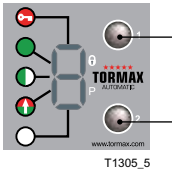

Browse through the fault display using selector key 1 upwards (to display several faults).

1. Reset the error message, press selector key 2 (downwards) briefly.
2. Software reset: press the key for 5 seconds.

Reset of the Fault with the Operating Mode Switch

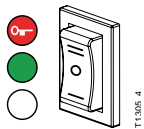

Software reset in the event of a fault: change the operating mode.

Reset of the Fault by Disconnecting the Power Supply

If the system does not have a battery unit, disconnect from the power supply for about 10 seconds.

If this does not reset the fault or if it re-occurs after a short time, you must arrange for the fault to be rectified by a specialist from your TORMAX dealer. In this case note the fault number and inform the dealer. See the last page or the service tag on the system for the dealer's address.

6 Maintenance

The system was tested and approved by an expert before initial commissioning. The manufacturer recommends that you conclude a service contract in order to maintain the value of your system for as long as possible as well as to ensure the system operates reliably and safely for a long time.

Only genuine TORMAX spare part should be used. The manufacturer accepts no liability if you fail to observe this requirement. Original spare parts and original accessories guarantee the safety of use in accordance with norm EN 16005.

The following maintenance work must be carried out:

6.1 Cleaning



Warning

Closing doors can crush – danger!

Trapped limbs can lead to serious injury.

- The system must only be cleaned in operating mode OFF, OPEN or Manual Operation.
- Clean casing parts, the user interface and door leaves with a damp cloth and a commercial cleaner.

6.2 Functional Checks

The operator must check the function and safety devices of the automatic sliding door at least every 3 months. This will ensure that faults or hazardous changes in the system are detected at an early stage. See section 7.2 “Check-list for Functional Checks” for items to be checked.

You should arrange for any defects detected during the routine checks to be rectified immediately by a TORMAX dealer (see the last page of this Manual for the address).



Warning

Potential switching malfunction in the automatic sliding door.

Potential hazards – injury caused by impact or crushing.

6.3 Maintenance and Testing

Maintenance and testing should only be carried out by a trained specialist following the manufacturer's instructions.

Maintenance Interval

The maintenance interval depends on the frequency of use but the system must be maintained at least once per year.

Scope of the Maintenance Work

The content of the maintenance work is specified by the manufacturer in an inspection list.

System Test Book

The test findings are recorded after the test in the system test book. The operator must keep it in a safe place.

7 Appendix

7.1 Fault Table

System Behaviour	No.	Cause	Remedy/ Rectification
The door stops when opening.	H91	Electronic obstacle recognition on opening by a person, wind pressure, ventilation or dirt in the floor guide.	Remove the obstruction. Clean the floor guide in operating mode P.
Door reverses when closing.	H92	Electronic obstacle recognition on closing by a person, wind pressure, ventilation or dirt in the floor guide.	Remove the obstruction. Clean the floor guide in operating mode P.
The door stops repeatedly when opening.	H93	Electronic obstacle recognition on opening in the same position by stationary obstacle.	Remove the obstruction. Clean the floor guide in operating mode P.
The door stops repeatedly when closing.	H94	Electronic obstacle recognition on closing in the same position by stationary obstacle.	Remove the obstruction. Clean the floor guide in operating mode P.
Search run notified.	H61 H62	Search run of the door after a reset or after power recovery.	Allow the search run to travel its full course.
Door operates at a reduced speed.	H71	Battery operation	Wait for power recovery Switch on mains supply.
Door remains closed.	–	Operating mode such as OFF, EXIT or P.	E.g. select operating mode AUTOMATIC 1.
Door remains open.	–	Operating mode such as OPEN or P.	E.g. select operating mode AUTOMATIC 1.
The door does not lock in OFF.	E11	Lock is jammed or defective.	Push the door leaves for a few seconds against the closed position in operating mode OFF when the door is closed. Have the system repaired by experts.
The door does not open after changing from OFF to AUTOMATIC. The lock makes switching noises from time to time.	E11	Lock is jammed or defective.	Push the door leaves for a few seconds against the closed position in operating mode AUTOMATIC 1. Have the system repaired by experts.
The door does not open in OFF when the key switch is used. The lock makes switching noises.	E11	Lock is jammed or defective..	Switch on with the key switch and then push the door leaves briefly against the closed position. Have the system repaired by experts.
Dependent on configuration.	E2 ...	Error in bus system	Have the system repaired by experts.
The door closes slowly.	E30 E34	The safety facility in the closing direction is permanently active (>1 minute) or defective.	Remove objects from within the range of the sensor(s). Otherwise have the system repaired by an expert.
Door remains closed.	E31 E37	The safety facility in the opening direction is permanently active (>1 minute) or defective.	Remove objects from within the range of the sensor(s). Otherwise have the system repaired by an expert.

System Behaviour	No.	Cause	Remedy/ Rectification
The door opens slowly.	E32 E38	The safety facility in the opening direction is permanently active (>1 minute) or defective.	Remove objects from within the range of the sensor(s). Otherwise have the system repaired by an expert.
The door remains open.	E33 E39	The safety facility in the closing direction is permanently active (>1 minute) or defective.	Remove objects from within the range of the sensor(s). Otherwise have the system repaired by an expert.
The door remains open.	E41 E42 E43	Activator inside is active > 1 min. Activator outside is active > 1 min. Key switch is active > 1 min.	Get sensor adjusted by a professional. Reset the key switch.
Door remains open.	E46	Emergency opening monitoring > 10 mins. active	Have the system repaired by experts.
The door stands still.	E51	Encoder defective.	Have the system repaired by experts.
The door stands still.	E53 E54 E55 E56	Anomaly in the travel distance. Solid obstruction in the movement area.	Remove firm obstacle in the travelling range of the door. Perform a software-reset. Have the system repaired by experts.
The door stands still.	E61 E62 E63	Power supply is overloaded or voltage too low.	Get the power supply and connections checked by a professional.
The door stands still.	E64 E65	Drive/control system is overheated.	Wait for the automatic reset after the door/control system has cooled. Protect from direct sunlight.
The door stands still.	E66	Motor control defective.	Have the system repaired by experts.
Normal operation	E67	Drive heavily loaded.	Wait for the automatic reset Otherwise have the system repaired by an expert.
Door remains open or normal operation.	E72	Battery charge < 15 %	Wait until battery is sufficiently charged
Door remains open or normal operation.	E73	Battery unit defective	Have the system repaired by experts.
The door stands still.	E8..	Control system shut down for safety reasons.	Perform a software-reset. Have the system repaired by experts.
The door collides with people.	–	Safety device or setting inadequate.	Shut down the system. (see section 2.6).

7.2 Check-list for Functional Checks

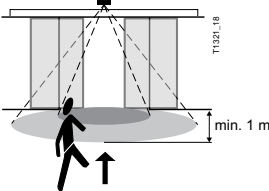
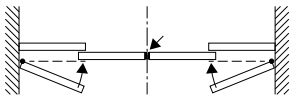
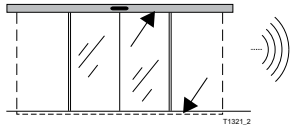
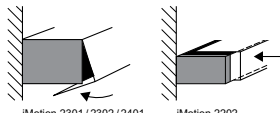
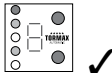
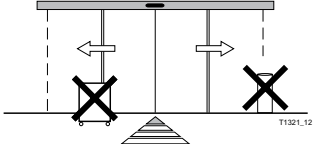
Item To Be Checked	Procedure	Result
Sensors		
	<ul style="list-style-type: none"> • Walk through the door directly from the front and from different directions at normal speed, starting both from the inside and outside • Walk through the door directly from the front and from different directions at a slow speed like an infirm person, starting both from the inside and outside. 	<p>The door opens at the right time and with sufficient speed so that passage through the door is not hindered.</p> <p>The door opens and remains open until you are completely through the door.</p>
Moving Leaves, Side Parts, Fixed Leaves		
	<ul style="list-style-type: none"> • Check the glass door fillings, door edges and rubber profiles for damage. 	<p>The door fillings have no sharp edges and splintered glass.</p> <p>The side parts and the door seals are in place and undamaged.</p>
Guide System and Door Guides		
	<ul style="list-style-type: none"> • Check the noises made while the door moves. 	<p>No unusual and noticeable movement noises can be heard in the drive, guide system or floor guides.</p>
Cladding		
	<ul style="list-style-type: none"> • Check whether the cladding is correctly slotted into place and secured. 	<p>The cladding is firmly slotted into place.</p>
Operating Controls		
	<ul style="list-style-type: none"> • Check the function and marking of operating controls. 	<p>The operating controls are functioning correctly; the markings are visible and legible.</p>
System Vicinity		
	<ul style="list-style-type: none"> • Check access to the door and the movement area of the door leaves. 	<p>Access to the door is free from objects and items likely to cause the user to trip. There are no objects such as shelves, plant containers and umbrella stands within a radius of 50 cm of the movement area.</p>



EG Declaration of Conformity

The manufacturer declares

Manufacturer's address: _____

that the product (machine)

Type designation: _____

Serial number: _____

is in conformity with the guideline EG-RL 2006/42/EG

is in conformity with regulations of the guidelines:

- 2006/95/EG (low tension)

- 2004/108/EG (electro-magnetic-compatibility)

and the following harmonised standards have been adhered to:

- EN 16005

Base document: Declaration of incorporation by TORMAX | Landert Motoren AG

Person responsible for documents

Name/address: _____

Place, date: _____

Signatory

(CE authorized person): _____

Signature: _____



the passion to drive doors

TORMAX Sliding Door Drives

TORMAX Swing Door Drives

TORMAX Folding Door Drives

TORMAX Revolving Door Drives

Manufacturer:

Advice, sales, installation
Repairs and service:

TORMAX | CH-8180 Bülach-Zürich

Phone +41 (0)44 863 51 11

Fax +41 (0)44 861 14 74

Homepage www.tormax.com

E-Mail info@tormax.com

TORMAX is a Division and a registered trademark of Landert Motoren AG

T-1689 e	Installation on Site	★★★★★ TORMAX AUTOMATIC TORMAX CH-8180 Bülach www.tormax.com info@tormax.com
Area of application	iMotion 2302 Sliding Door Drive	
Release	4 December 2013	
Use	Installation, Maintenance	

Contents

1	Installation	1
1.1	Installation Variants	1
1.2	Installation Hints	1
1.3	Installation of Header Profiles	2
1.4	Installation of Components	3
1.5	Installation of the Sliding Leaves	4
2	Mechanical Adjustments	4
2.1	Aligning the Sliding Leaves	4
2.2	Adjusting the Counter Rollers	5
2.3	Checking the Grounding	5
2.4	Adjusting the Lock Clearance	5
2.5	Cladding	6
3	Checking the System	7
4	Overview iMotion 2302	8
5	Overview iMotion 2302.R	9

Applicable documents

Download see TORMAX Extranet.

Recommended Tools

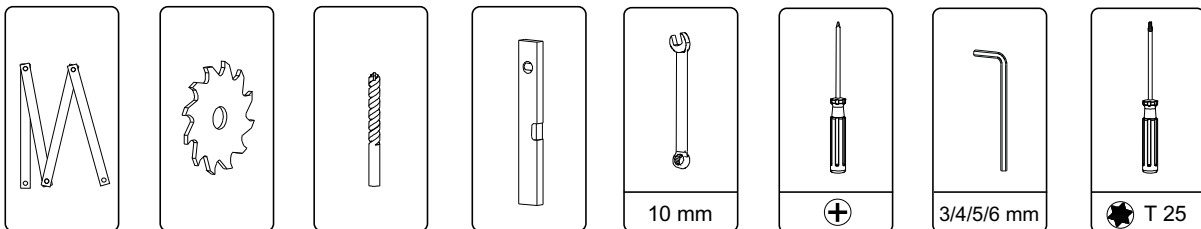

T1689_13

1 Installation

1.1 Installation Variants

Install the system respecting the installation alternatives and using the corresponding dimensional drawings (Download see TORMAX Extranet). In these dimensional drawings the cross section has to be replaced by T4_390_700 (adjust door leaf height).

It is imperative to respect these drawings, to ensure a correct assembly and a safe function of the system.

Applicable profiles

LR 12

LR 22B

LR 32Therm

with or without fixed leaves



Prior to installation respect the safety regulations according to the document T-1243 Safety during installation.

1.2 Installation Hints

For installation sequences, letters e. g. **(A)** **(B)** are used in the detail drawings.

1.3 Installation of Header Profile

Preconditions

- The profile has been prepared according to the instructions in T-1687, components assembly.
- The drive components have been pre-installed according to the instructions in T-1687, components assembly. Likewise the components can be installed after the installation of the header profile.

Header profile

- Drill the installation holes in header profile after the installation of the components.



CAUTION: The header profile supports weights of up to 360 kg on double-leaf doors. The number of mounting points and the mounting type must be dimensioned sufficiently in accordance with the ground.

- Stick the type label to the inside of the supporting profile at a well visible place on the left.

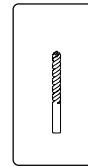
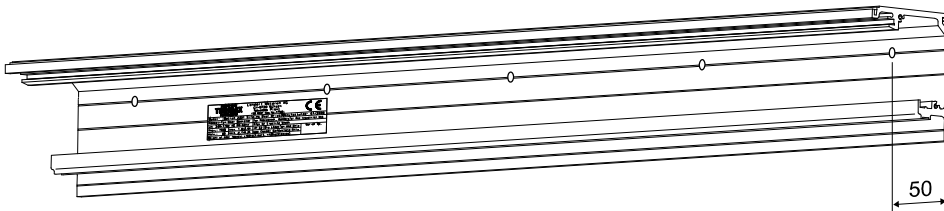

Installation of header profile on lintel

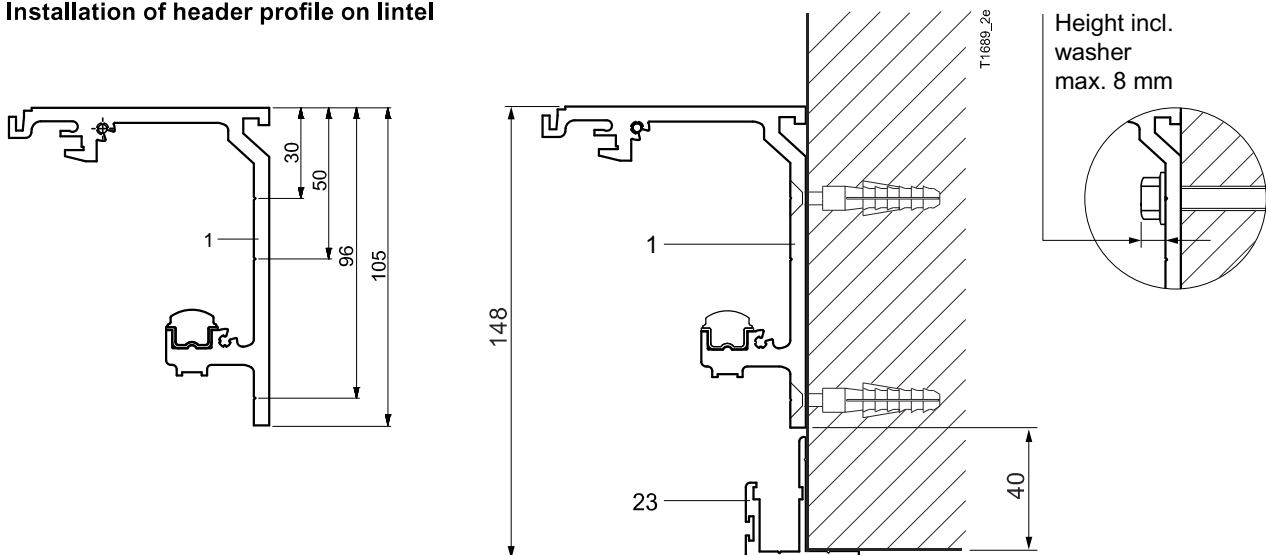

Example for 2-leaf unit EB for symmetrical arrangement

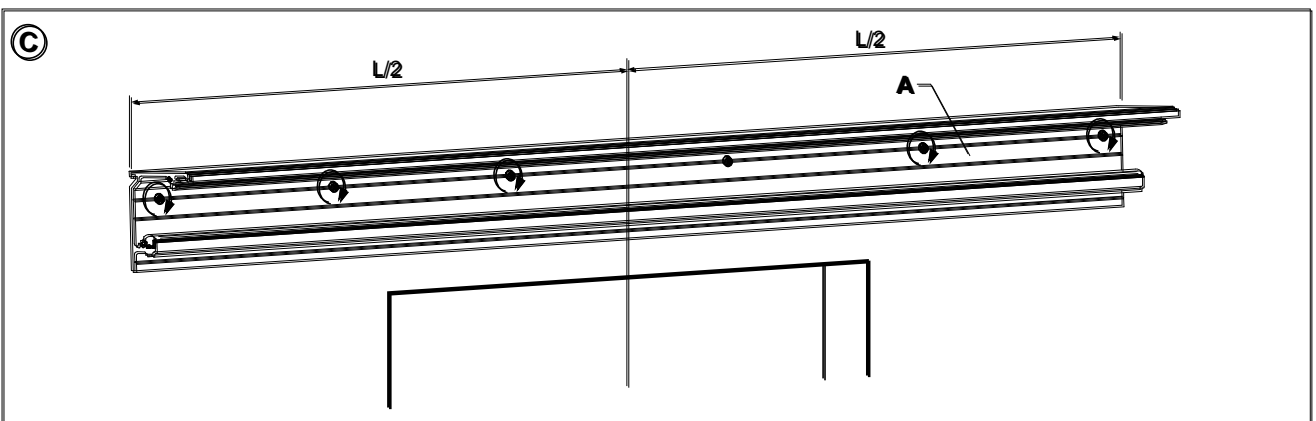
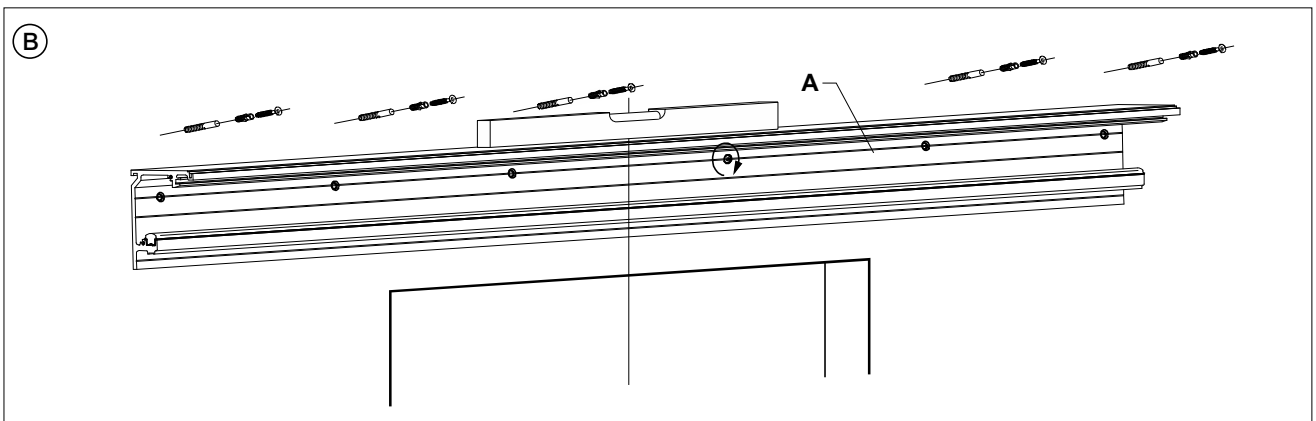
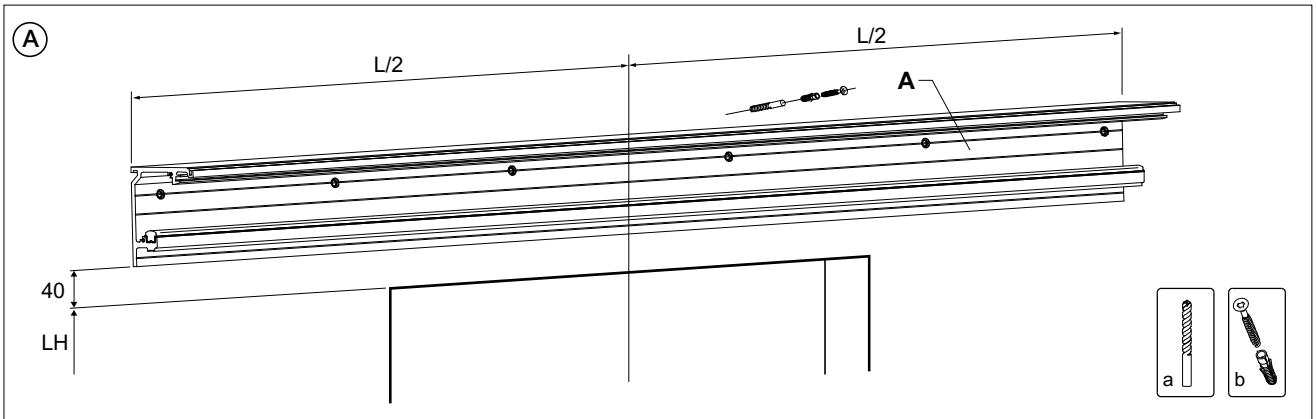

T1689_4

Adaption of installation surface

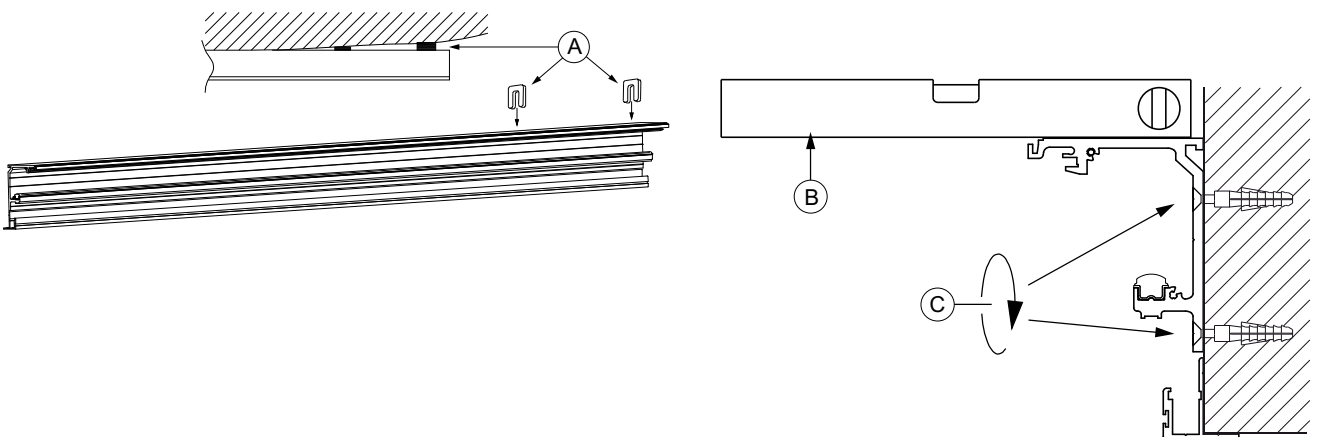

1.4 Installation of Components

T1689_3

- Install drive components according to T-1687, components assembly, if not yet done.

1.5 Installation of the Sliding Leaves



Depending upon leaf weight a second person must be available for the installation.

Assembly aid

Provisionally mountable assembly aid ◆ (D); prevents the trolleys (9) from tipping over when mounting the door leaf.

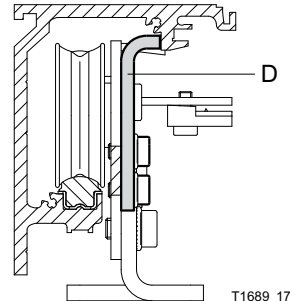
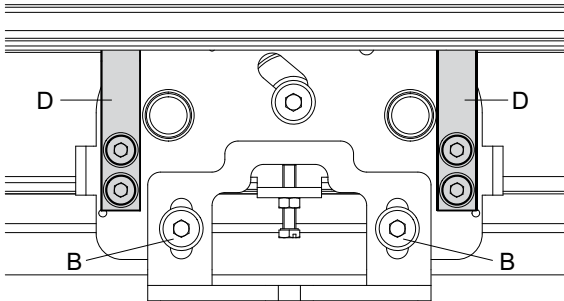

T1689_17

Mount sliding leaf

Important: If a lock is used, the dimensions $91 \text{ mm} \pm 1 \text{ mm}$ for EB, $172 \pm 1 \text{ mm}$ for ER / EL must be observed.

Ideally, use door leaves with relocatable fastening positions, e.g. groove blocks.

For Dimension c see T-1687 components assembly.

- Mount the door leaf in the trolley.
- Tighten screws A and B (on the trolley) until alignment is still just possible.

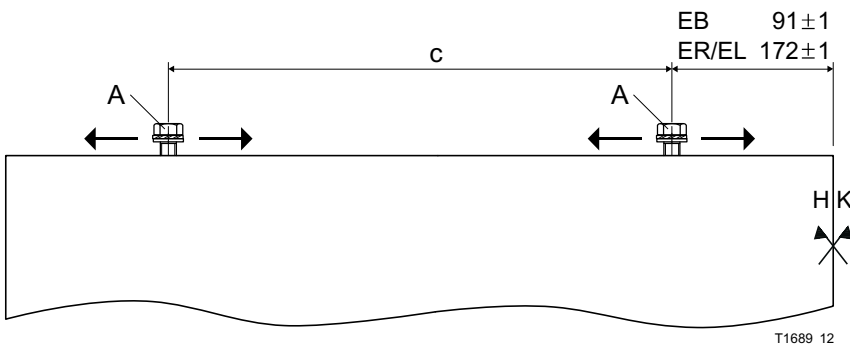

T1689_12

2 Mechanical Adjustments

2.1 Aligning the Sliding Leaves

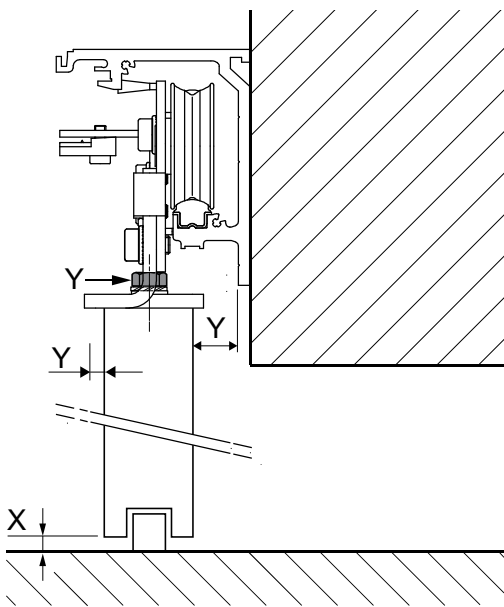

T1689_6

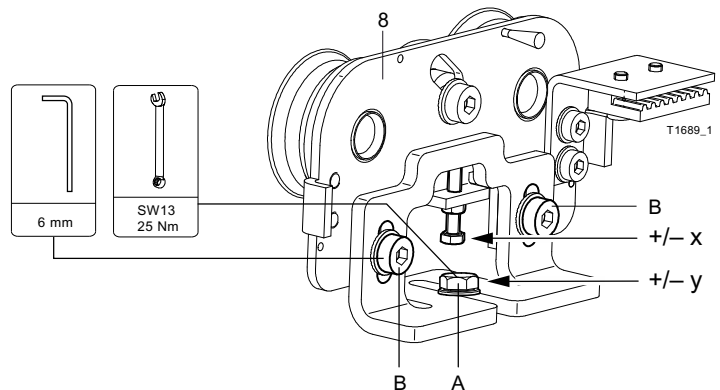

Order of work when aligning

1. Align the door leaf parallel (Y) to the header profile.
2. Align height and parallelism (X) to the header profile.
3. Align door leaves to one another.
4. Fully tighten screws A
5. Fully tighten screws B
6. Remove assembly aids again ◆.

2.2 Adjusting the Counter Rollers

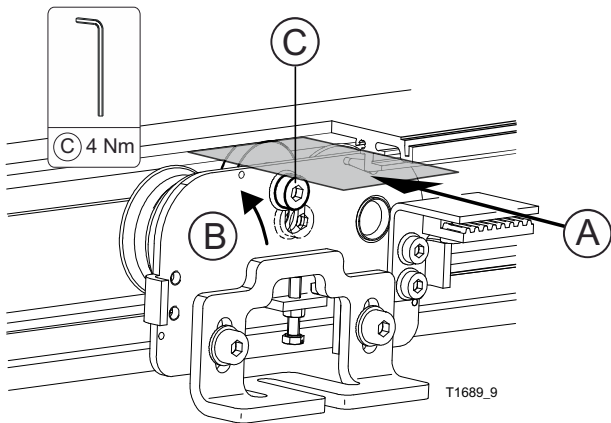

2.3 Checking the Grounding

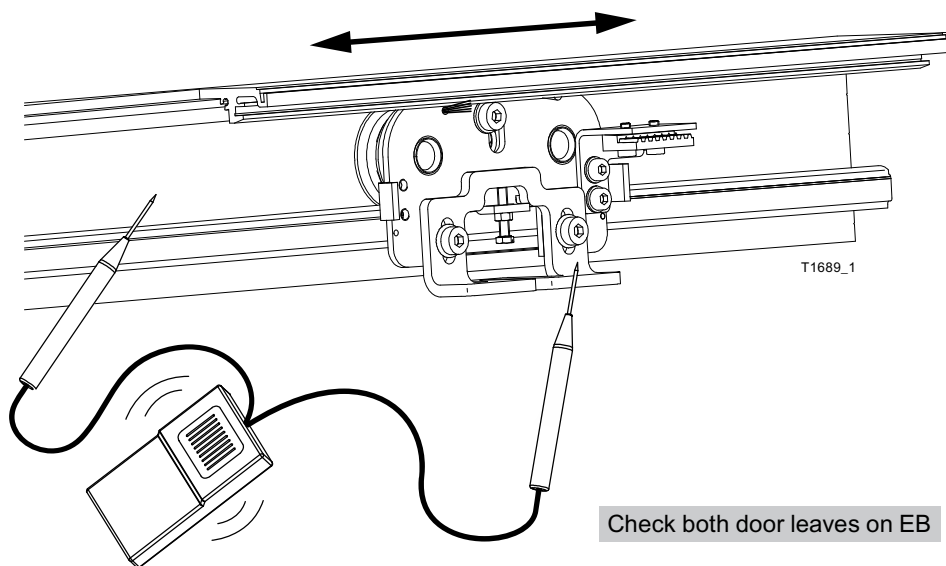

2.4 Adjusting the Lock Clearance

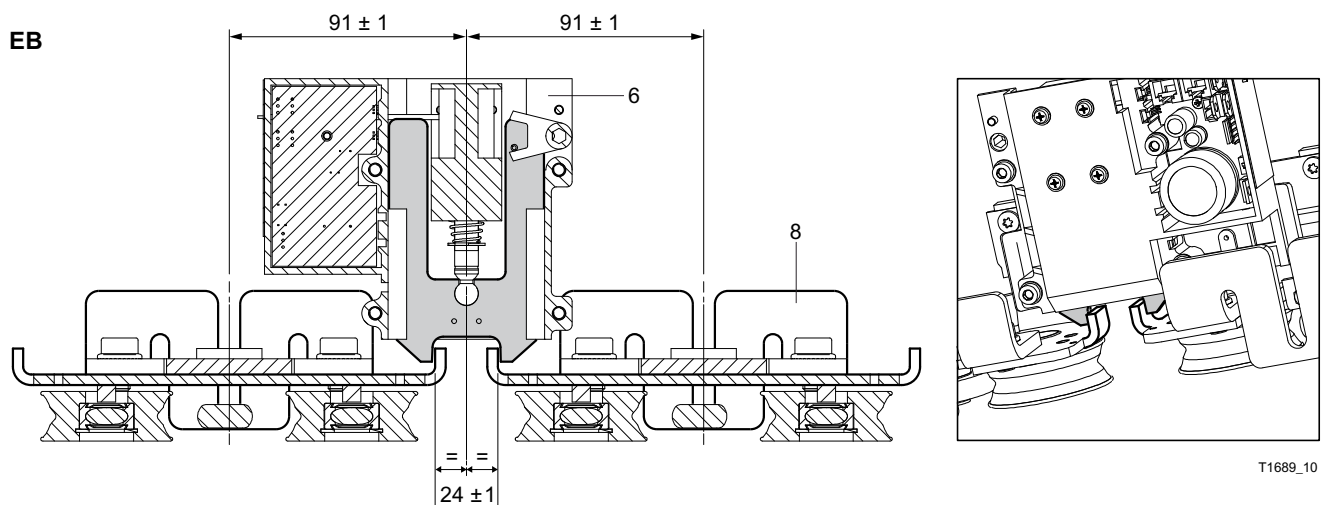

- Align lock in the middle.
The locking cams may not contact the slide latch – distance min. 1.5 mm.

ER / EL

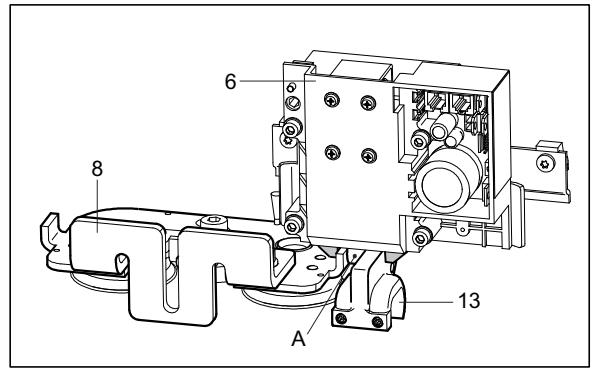
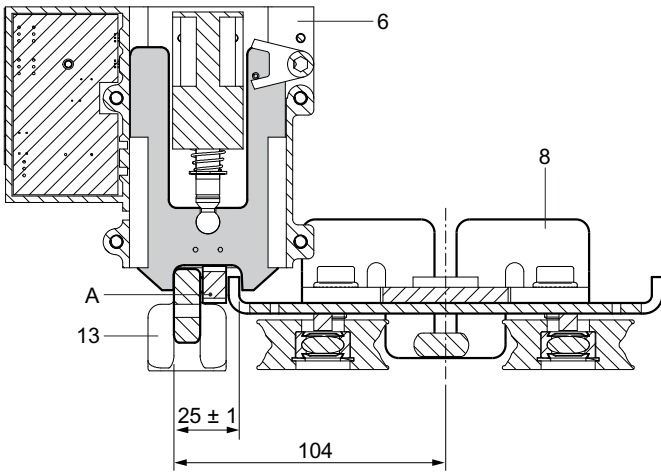

T1689_14

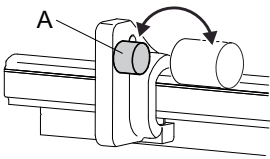

For ER / EL, a short buffer (A) has to be mounted on the end stop (13) .

- Align lock to locking cam – distance 0.5 mm.
The locking cam on the trolley has to touch the buffer (A) if the door is closed.

2.5 Cladding

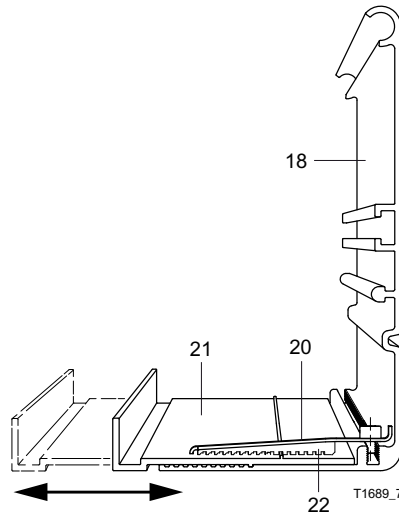
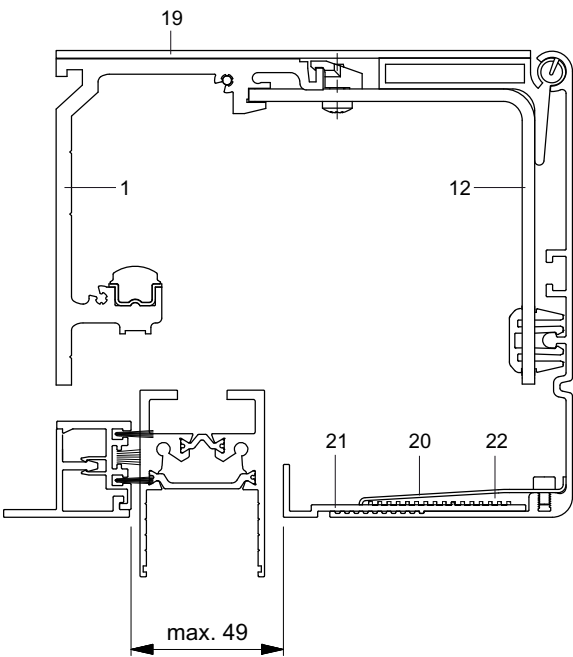

T1689_7

- Insert clamping plate (20) with locking rail (22) every 0,5 m.
- Mount side plates (17).

- Insert with a firm hit

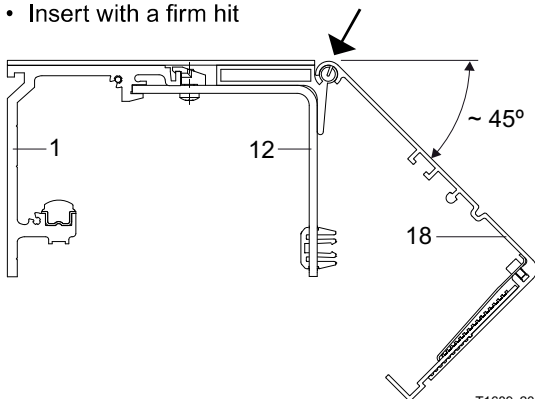

Best position for mounting/removal

T1689_20

Affix cover

- Fix adhesive tape (A) to cover (19) at front and at the side. Leave approx. 5 mm protruding over the edge.
- Place cover (19) on the edge of the cladding (18) and fix with adhesive tape (B) on impost section (1).
- Position side plates (17) and fix with overlapping adhesive tape.

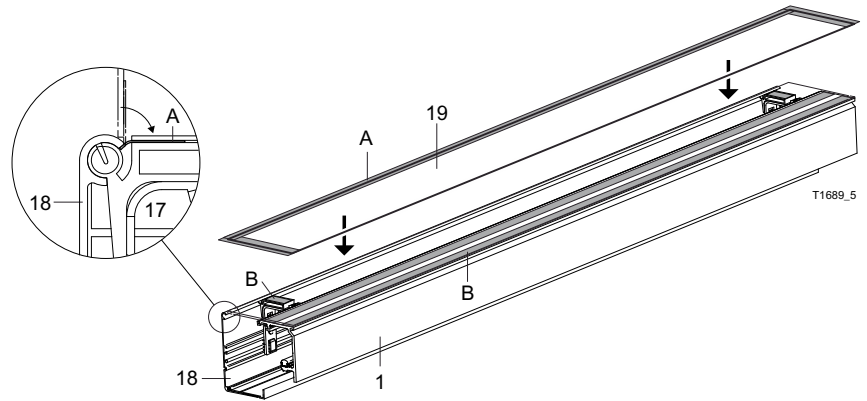

In this manner, the drive fulfils the requirements on IP 22, otherwise IP 20.

Hold open clamp

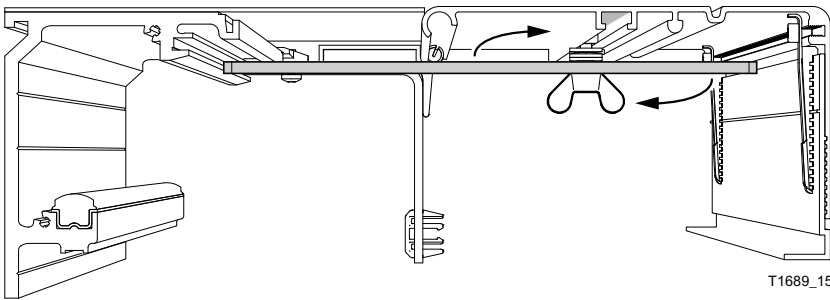

Manual Disengagement

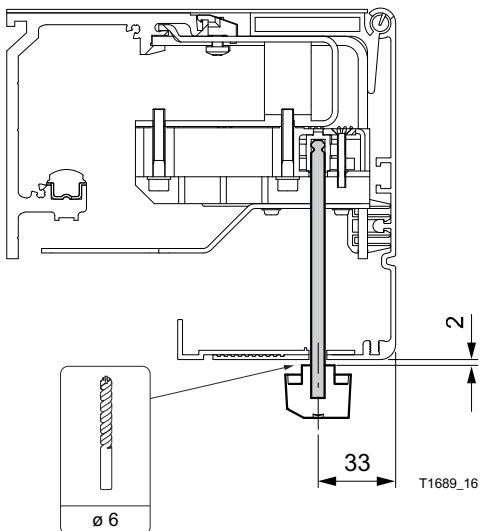

3 Checking the System



Before handing over to the user, the system must be checked according to the document T-1280 Examining the System and according to the checklist for first check 2302, 2302.R on the TORMAX Extranet.

4 Overview iMotion 2302

Opening to both sides EB

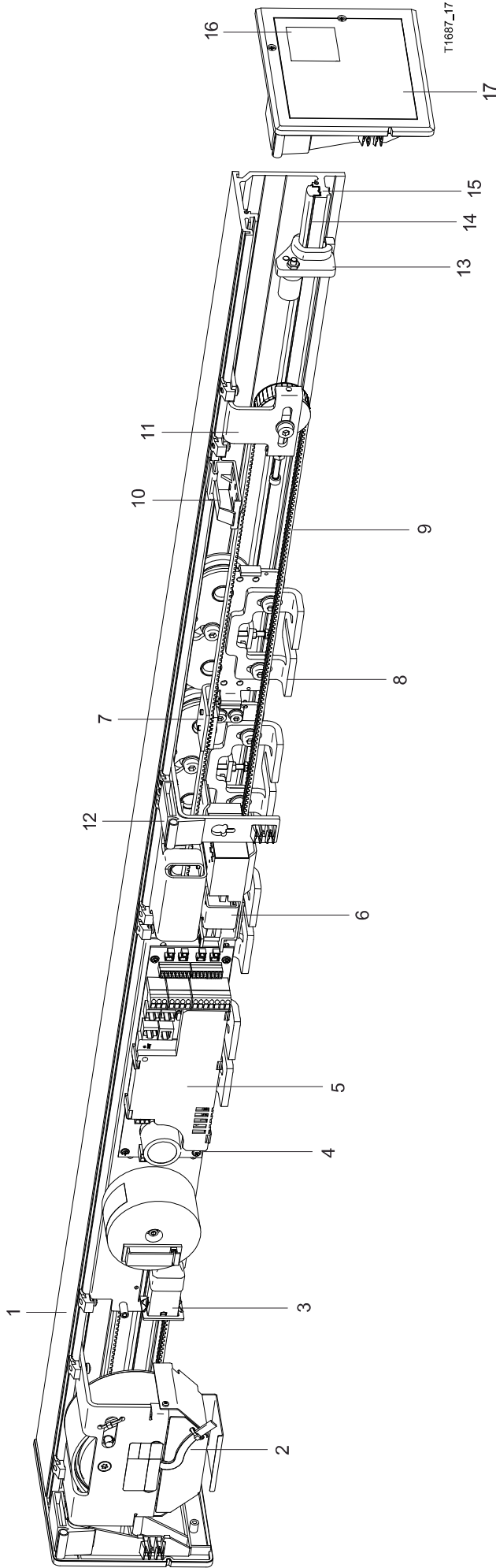

- | | |
|---------------------|--|
| 1 Header profile | 13 End stop |
| 2 Motor unit | 14 Guide rail |
| 3 Mains connection | 15 Shaped rubber band |
| 4 Fuse 5 AT | 16 Blind cover |
| 5 Control unit | 17 Side plate |
| 6 Lock | 18 Cladding |
| 7 Driver | 19 Cover |
| 8 Trolley | 20 Clamping plate for L-profile |
| 9 Toothed belt | 21 L-Profile |
| 10 Cable clip | 22 Locking rail |
| 11 Deflection unit | 23 Wall connection profile LR12/LR 22B |
| 12 Cladding support | 24 Wall connection profile LR32 THERM |

5 Overview iMotion 2302.R

Opening to both sides EB

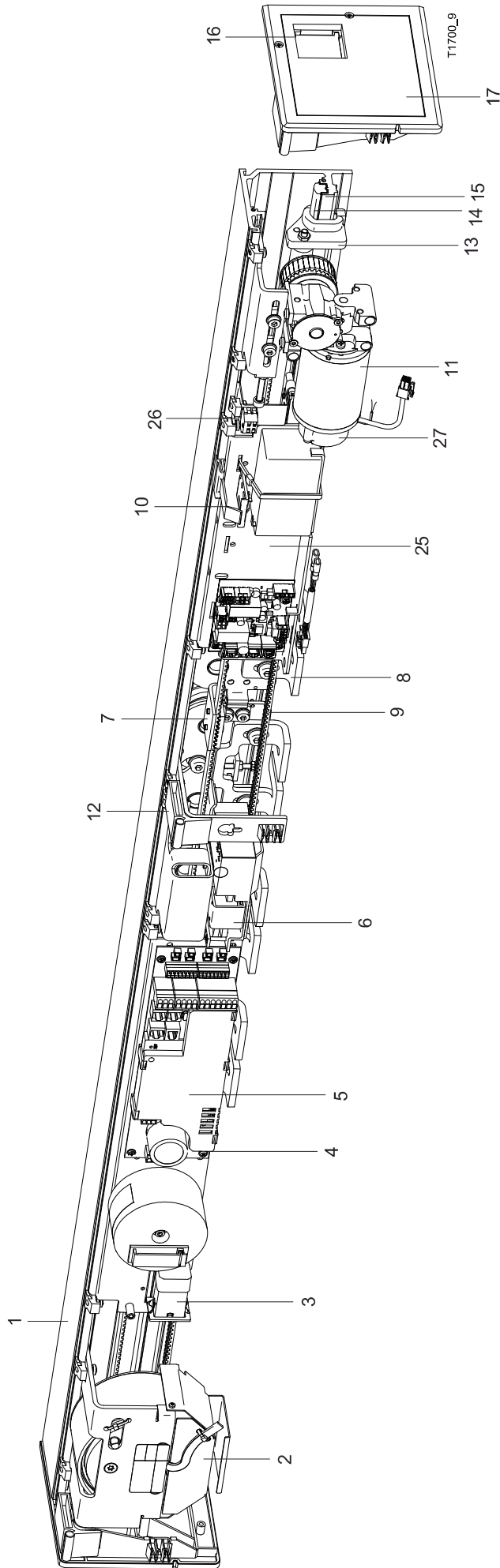

- | | |
|---------------------|--|
| 1 Header profile | 14 Guide rail |
| 2 Main motor | 15 Shaped rubber band |
| 3 Mains connection | 16 Blind cover |
| 4 Fuse 5 AT | 17 Side plate |
| 5 Control unit | 18 Cladding |
| 6 Lock | 19 Cover |
| 7 Driver | 20 Clamping plate for L-profile |
| 8 Trolley | 21 L-Profile |
| 9 Toothed belt | 22 Locking rail |
| 10 Cable clip | 23 Wall connection profile LR12/LR 22B |
| 11 Auxiliary motor | 24 Wall connection profile LR32 THERM |
| 12 Cladding support | 25 Escape unit |
| 13 End stop | 26 Position switch 80 % |